



MADHUS
Garage Equipment

MADHUS

ER65

WHEEL BALANCER



**FULL FEATURED
EUROPEAN WHEEL BALANCER
WITH MADHUS SERVICE SUPPORT**

MADHUS ER65

Premium Wheel Balancer at an Affordable price

- VDD Virtual Direct Drive - very quick and maintenance free measurement system **Patented**
- Lock of wheel in the correction position by means of an **electromagnetic brake**
- Software programs for the professionals: **SPLIT, OPT, ALU**
- **Extended gauge** for diameter and distance measurement of rims up to 28" with new pincer to hold the adhesive weight
- **ALU-S balancing mode** (adhesive weights on the internal rim planes) with specific counterweight position indicator (position repeater)
- **LASER** for weight positioning inside the rim
- **Automatic approach** of the wheel within 15° from the point of application of the balancing weight, to allow the operator to position it correctly
- **ER65SE - Pneumatic wheel locking** Floor to floor time reduction / Extremely easy and quick to use / Very accurate wheel centering **Patented**



Virtual Sonar

Innovative 3d software that calculates rim width



AutoAdaptive Mode

Innovative tolerance calculation system

TECHNICAL SPECIFICATION

Single phase power supply	115 / 230 V 50/60 Hz
Max. absorbed power	0,15 kW
Balancing speed	100 rpm
Measuring cycle for 15 kg wheel	4.7 s
Measurement uncertainty	0,5 g
Avarage noise	< 70 dB (A)
Rim width setting range	1.5" ÷ 20" / 40 ÷ 510 mm
Rim diameter setting range	10" ÷ 30" / 265 ÷ 765 mm
Max. wheel weight	< 75 kg
Machine weight	120 kg

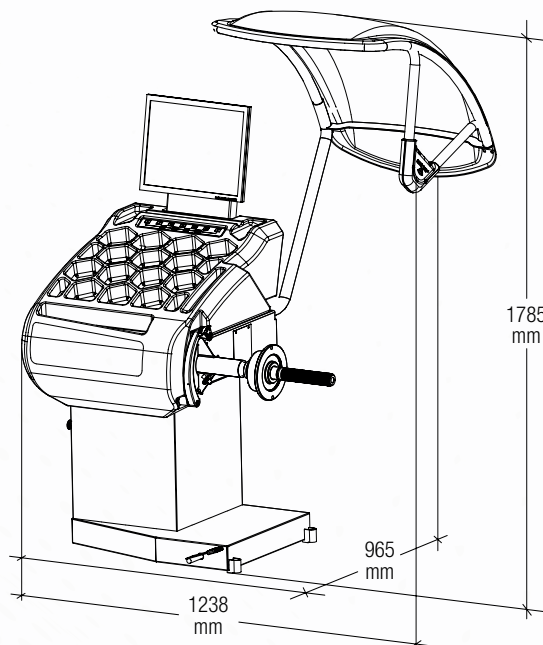

Corporate Office:

46/2, Doddakallasandra, Konanakunte Cross, Kanakapura Road, Bangalore - 560 062
Phone: 080 4095 3488 Email: madhus@madhusindia.com | www.madhusindia.com